

PCB-LAYOUT

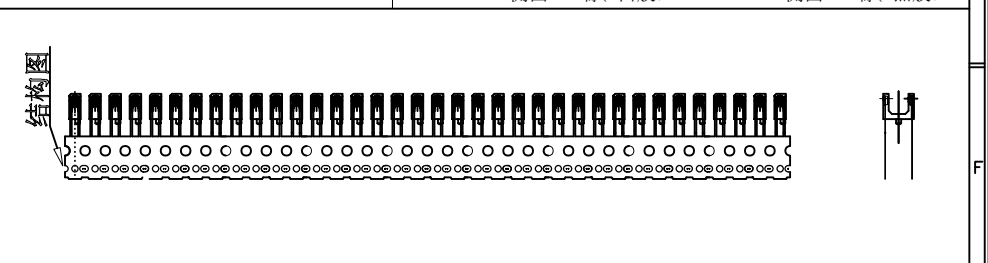
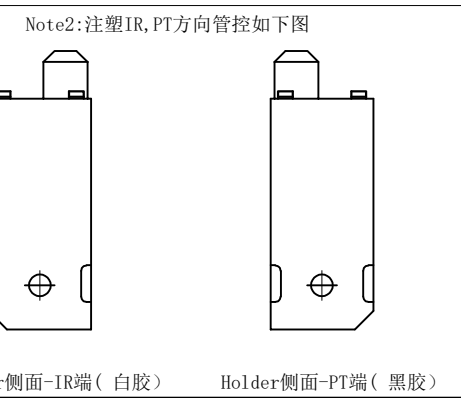
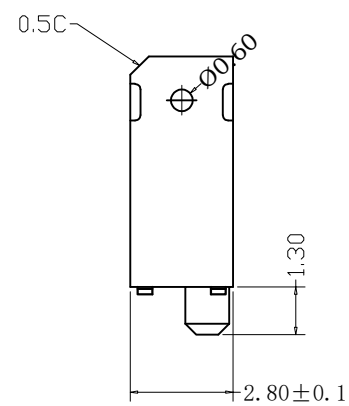

技术资料:

1. 毛边规格: 分模面毛边凸出不得超过0.1MM, Pin脚毛边凸出不得超过0.2MM
2. 压Pin脚宽度尺寸不得超过0.45MM, 料带不允许折痕
3. 产品表面不允许漏铜, 以及残留铜屑, 光窗口不允许有毛边
4. 塑胶材料: PA9T

GENERAL TOLERANCE		制图 Mapping	料号 PART NO.	P50001WVS	版本 REV.	A
X.±0.25	X.'±2'	审核 Audit	品名 TITLE	ITR-1203D-C版-SMT-36	页次 SHEET	1/1
.X±0.20	.X'±1'	核准 Approved	客户料号 CUTM. NO.			
.XX±0.15	.XX'±0.5'	单位 Units	广州市恒炜电子有限公司 GuangZhou HengWei Electronic Co., Ltd			
.XXX±0.10	.XXX'±0.5'	MM	比例 SCALE	1:1		