

技术参数SPECIFICATIONS

- 1、极数CKT: 2Pin
- 2、工作电压(VDC): 250
- 3、标称电压架构(V): 12, 24, 42, 48, 80, 90, 125, 240
- 4、工作温度Working Temperature: -40-125° C
- 5、保护等级: IP67

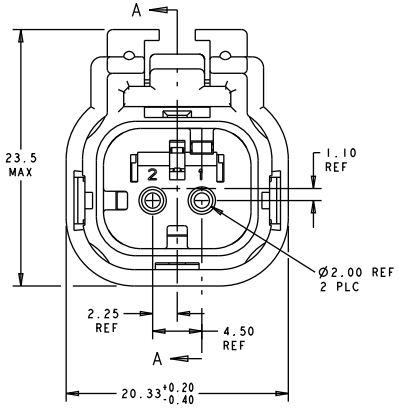

776427-1 SHOWN KEY A

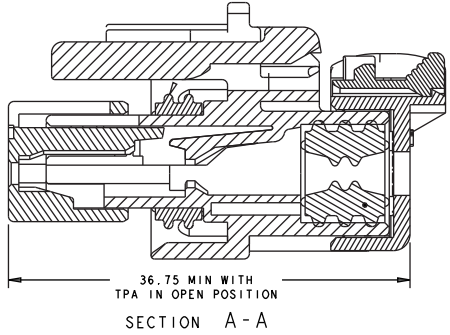

SECTION A-A

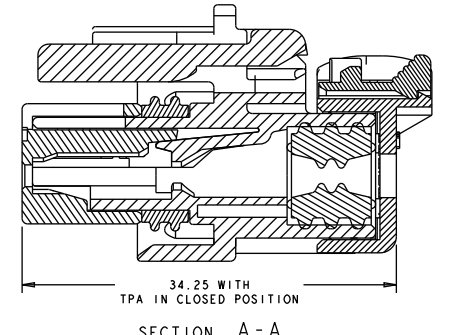

SECTION A-A

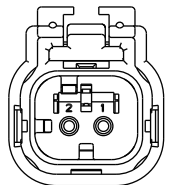
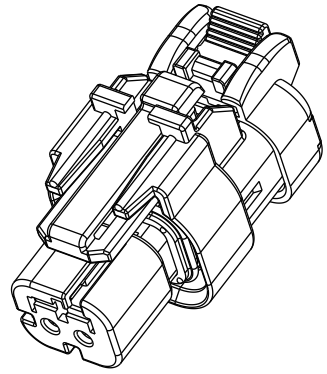

776427-2 SCALE 2:1 KEY B

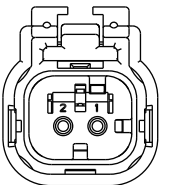

776427-3 SCALE 2:1 KEY C

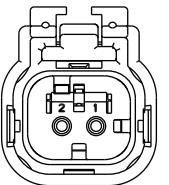

776427-4 SCALE 2:1 KEY D

连接器系统: 线到线
 连接器和壳体类型: 母端子护套
 外壳材料: PBT GF

制图 DRAWN	变更内容 DESCRIPTION	日期 DATE	GENERAL TOLERANCE		制图 Mapping	郑 弋 2024.03.11	料号 PART NO.	HWCH021S-1.5-21		版本 REV.	A
			X.±0.25	X.±2°				品名 TITLE	页次 SHEET		
			.X±0.20	.X±1°	审核 Audit	张 名 2024.03.11	客户料号 CUTM. NO.				1/1
			.XX±0.15	.XX±0.5°	核准 Approved	杨 斌 2024.03.11					
			.XXX±0.10	.XXX±0.5°	单位 Units	MM	比例 SCALE	1:1	广州市恒炜电子有限公司 GuangZhou HengWei Electronic Co., Ltd		